



IMER *U.S.A. inc.*

MASONRY 500 Sawing machine

Model - 1188804

EL

**MANUAL INSTRUCTION
and
PARTS LIST**



Manual Part. number 3210720 R00 - 07/2002

Machine serial N°

--	--	--	--	--	--	--	--	--	--

Write in the serial n° of your machine here



Thank-you for purchasing a **Masonry 500** from an Imer U.S.A. dealer. Your decision is an intelligent one.

There is no other sawing machine in the world which delivers the benefits and features of the Masonry 350F:

- Extremely rigid, mig welded bar steel frame.
- 5.5 H.P. electric motor.
- Single arm for larger working space.
- Extremely rigid worktable for a precise cutting.

At IMER U.S.A. we continually search for ways to better serve our customers. Should you have an idea or thought to share with us regarding this product we would appreciate hearing from you. Our motto is **"Tools and Services for the 21st Century"**. We look forward to delivering the goods.

Thank you again for your purchase.

Mace T. Coleman, Jr.
President, Imer U.S.A, Inc.

IMERWEST
207 Lawrence Avenue
So. San Francisco, CA 94080
Tel 650 - 872 - 2200
Fax 650 - 873 - 6482

IMEREAST
221 Westhampton Place
Capitol Heights, MD 20743
Tel 301 - 336 - 3700
Fax 301 - 336 - 6681

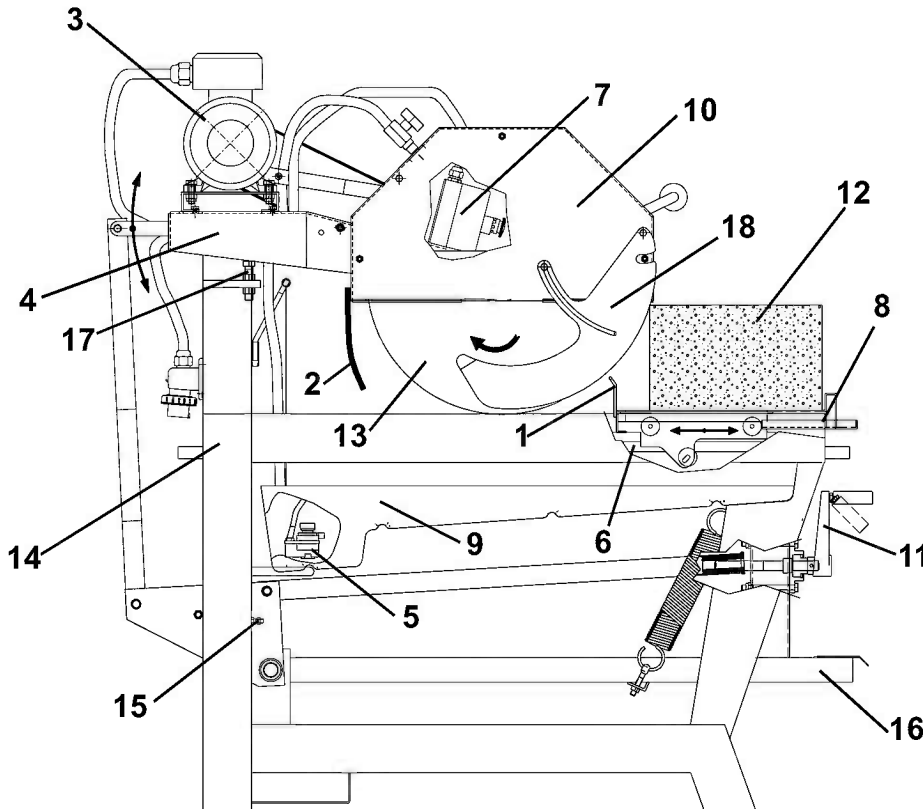

1. Carriage locking lever.
2. Spray guard
3. Electric motor
4. Blade support
5. Water pump
6. Guide
7. Contactor
8. Worktable
9. Water tank
10. Blade cover
11. Adjustment crank.
12. Work piece
13. Blade
14. Frame
15. Earth screw
16. Pedal.
17. Head stop bolt.
18. Blade guard.



Dear Customer,

Congratulations on your choice of purchase: this IMER saw, the result of years of experience, is a fully reliable machine and is equipped with the latest technical innovations.

⚠ - WORKING IN SAFETY

To work in complete safety, read the following instructions carefully.

- This OPERATION AND MAINTENANCE manual must be kept on site by the person in charge, e.g. the SITE FOREMAN, and must always be available for consultation.
- This manual is to be considered an integral part of the machine, and it must be preserved for future reference (EN292/2) throughout the machine's normal working life. If the manual is damaged or lost, a replacement may be requested from the saw manufacturer.
- The manual contains important information regarding site preparation, installation, machine use, maintenance procedures and requests for spare parts. Nevertheless, the installer and the operator must both have adequate experience and knowledge of the machine prior to use.
- To guarantee complete safety of the operator, safe operation and long life of equipment, follow the instructions in this manual carefully, and observe all safety standards currently in force for the prevention of accidents at work. Use personal protection (safety footwear, suitable clothing, gloves, goggles, etc.).

⚠ - Safety glasses or a protective visor must be worn at all times.

⚠ - Ear protection must be worn at all times.

⚠ - MAKE SURE THAT WARNING SIGNS ARE ALWAYS LEGIBLE.

⚠ - It is strictly forbidden to carry out any form of modification to the steel structure or working parts of the machine.

- IMER INTERNATIONAL declines all responsibility for non-compliance with laws and standards governing the use of this equipment, in particular; improper use, defective power supply, lack of maintenance, unauthorised modifications, and partial or total failure to observe the instructions contained in this manual.

IMER INTERNATIONAL is entitled to modify the characteristics of the sawing machine and/or the contents of this manual without necessarily updating previous machines and/or manuals.

1. TECHNICAL DATA

Table 1 shows the saw's technical data, referring to figure 1.

TABLE 1 - TECHNICAL DATA (1188804)		
Blade rpm	rpm	2.300
Blade diameter	in.	20" - (22")
Blade mounting hole	in.	1"
Engine type		Electric
Power engine	Hp	5,5
Motor rpm	rpm	3.380
Cutting table dimension	in.	20"x17"
Overall dimensions (widthxlengthxheight)	in.	28"x62"x62"
Overall dimensions for transport (widthxlengthxheight)	in.	28"x62"x67"
Weight	lb.	465
Weight for transport	lb.	515
Blade rotation direction(seen from blade clamping flange)		CLOCK WISE

2. DESIGN STANDARDS

MASONRY 500 saws are designed and manufactured according to the following standards: EN 292-1-2; EN 12418; 89/336/CEE; 2000/14/CE.

3. NOISE EMISSION LEVEL

Table 2 indicates the environmental noise levels measured for the panel saw (L_{WA}) in accordance with EN ISO 3744 and the acoustic pressure level measured at the operator's ear with the machine empty (L_{PA}).

TABLE 2 - [dB(A)]			
SAWING MACHINE	TYPE OF MOTOR	L _{PA}	L _{WA}
Masonry 500 EL	ELECTRIC MOTOR	95	107

4. CUTTING SPECIFICATIONS

This saw model has been specially designed for cutting stone, ceramics, marble, granite, concrete and similar materials. Only water-cooled diamond blades with continuous or segmented edges must be used. Under no circumstances must dry cutting blades be used or materials other than those specified above. IMER INTERNATIONAL declines all responsibility for damage caused by improper use of the above machine.

5. CUTTING CAPACITY

- max. cutting capacity with vertical blade = 8" in. in one single pass.
- max. height of workpiece: 16½" in.
- min. width of workpiece: 2".
- max. cutting length: 17" (with blade lowered), 27"(vertical movement of the disk).
- Blade at 45°: with support at 45° on the work surface.

6. WARNING

- Do not load the saw with workpieces that exceed the specified weight (max. 90 lb.)
- Ensure stability of machine: it must be installed on a solid base with a maximum slope of 5° (fig. 2).
- Ensure the workpiece is stable before, during and after cutting: in any case, workpieces must not overhang the worktable.
- Respect the environment; use suitable receptacles for collection of cooling water contaminated with cutting dust.

7. SAFETY PRECAUTIONS

- IMER saws are designed for work on construction sites and under conditions of natural light, hence the workplace must be adequately lit.

⚠ - The machine must never be used in environments subject to risks of explosion and/or underground sites

- IMER saws may only be used when fitted with all required safety devices, which must be in perfect condition.
- Never use makeshift and/or faulty power cables.
- Make electrical connections on the construction site where they will not be subject to damage. Never stand the saw on power supply cables.
- Lay power cables in such a way as to prevent water penetration. Only use connectors fitted with water-spray protection (IP57, EEC).
- Repairs to electrical installations must only be carried out by qualified technicians. Always ensure that the machine is disconnected from the power supply and is completely immobile during repairs and maintenance operations.

⚠ - Connect the machine to a suitable equipotential earthing plant on the construction site with wire braid of minimum 16 mm² section. The connection point is identified by a screw welded to the frame (Ref. 15, fig.1), and on the rating plate by the earthing symbol.



⚠ - Stop the saw only by means of the main switch (Ref. 7, fig. 1).



Fig. 3

8. ELECTRICAL SAFETY

IMER saws comply with EN 60204-1; and are fitted

- with:
- Protection device against automatic re-start after power failure.
- Short-circuit cutout device
- Motor overload cutout switch.

9. TRANSPORTATION (fig.4)

⚠ - Warning. Before removing the panel saw, lock the carriage using the stop (ref. 4, fig. 4). When transporting the machine, use a four-arm tie rod (ref.1, fig.4) engaging the hooks in the connectors provided (ref.3, fig.4). When transporting the machine with a fork lift, insert the left fork in the slot provided (ref.2, fig.4).



10. INSTALLATION (fig. 4)

- Lift the machine out of its package using slinging equipment with 4 rope legs. Fix the hooks to the relative attachments.
- Install the machine on a completely even and stable surface.
- Release the carriage from the lever that secures it to the frame.

11. ELECTRICAL CONNECTION

- Ensure that there is an overload cutout device fitted up-line on the power line.

- Ensure that the mains voltage corresponds to that specified for the machine: 230V/60Hz. The electrical power cable must be suitably sized to avoid voltage drops. Cable drums must not be used.

Connect the machine to an efficient earthing system.

The size of the power cable wires must be based on operating current and length of the power line to prevent excessive voltage drops (ref. Table 3).

Cables used on construction sites must be fitted with suitable external sheathing that is resistant to wear, crushing and extreme weather conditions (for example H07RN-F).

- All power supply installations must comply with CEI 64-8 standards (harmonised document CENELEC HD384).

12. MACHINE START-UP

Before connecting the machine to the power supply:

- 1 - Ensure that the metal structure is connected to an earthing plant as indicated in Section 7 "Safety Precautions".
- 2 - Ensure that the tank contains sufficient cooling water.
- 3 - Ensure that the power circuit corresponds to the requirements as indicated in Section 11 "Electrical connections"
- 4 - Connect the machine to the power supply
- 5 - Press the black switch (Ref. 7, fig. 1).

- If rotating direction is opposite to the arrow on the guard, stop the machine and reverse the two wires inside the feeding plug: such operation must be carried on by reliable persons

6 - adjust the flow of cooling water by turning the cock next to the blade guard (do not perform cutting without water).

7 - Check that the direction of blade rotation corresponds to that indicated by the arrow on the blade guard.

8 - If all is in order, proceed with cutting.

13. EMERGENCY STOP

- In an emergency, stop the machine by pressing the stop control switch.

- The motor is fitted with an overload cutout device. If the motor overheats, it will automatically shut down. Allow the motor to cool and press the black switch on the overload cutout device to restart (Ref. 7, fig. 1).

- The motor is protected against automatic re-start after interruptions due to power failure. To resume operation, when power is re-connected, press the black switch on the overload cutout device (Ref. 7, fig. 1).

14. BLADE INSTALLATION (Fig.5)

By means of a hex wrench no.10, unscrew the 5 screws that lock the moving blade guard (ref.3). Use a hex wrench no. 13 to remove the screw that locks the flanges on the disc: this screw has a left-hand thread (rif.1). Remove the mobile flange (rif.2) and check that the flanges, disc shaft and blade are not damaged.

- Never use worn blades or blades with missing segments.

- Only use blades that are designed for the number of revolutions indicated on the machine rating plate.

- Check that blade rotation corresponds to that indicated on the blade guard.

Centre the blade against the fixed flange, position the mobile flange and tighten the securing screw by means of a hex wrench no. 13 (turn clockwise). Refit the moving blade guard, tightening the 5 screws (ref.3).

- Ensure that the blade guard (ref.3) is locked securely into position.

- **WARNING!** An incorrectly installed blade, or a screw insufficiently tightened can provoke damage to the machine or injury to persons.

Note that the blade must have an external diameter of 20" in. a central hole diameter of 1" in. and max. thickness of 1/8" in.

- Check that the blade to be used is suitable for the material to be cut.

- Do not use blades for wood! (fig. 6).

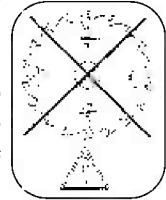

Fig. 6

15. USE

- Leave a space of 5 ft. around the machine to operate in full safety.

- Do not allow other persons to approach the machine during cutting.

- Never use the machine in fire-risk areas. Sparks can cause fire or explosions.

- Make sure that the machine is switched off before positioning or handling.

- Always ensure that the blade is free of any contact before start-up.

- Ensure correct installation of all protective devices.

Before starting work, fill the water tank. Top up during operation whenever necessary: N.B. the pump suction hose must always remain immersed in water.

- Insert the plug in the power socket.

- **WARNING!** For safety purposes the removal of protective guards from the machine is strictly prohibited. The machine is protected against overload: this protection triggers stopping the machine, after which the time necessary for the overload to cool must pass before it is possible to restart the machine.

- **WARNING!** Always switch off the machine before carrying out blade adjustment.

15.1 VERTICAL MOVEMENT OF THE DISK.

To raise or lower the cutting wheel, turn the crank (ref.11, fig.1) until the wheel is at the required height above the cutting table. The wheel can also be lowered by pressing the pedal (ref.16, fig.1); when the pedal is released the cutting wheel will return to the position originally set using the crank.

- Ensure that the locking handle is tightened fully before starting work.

15.2 POSITIONING FOR 45° CUTS.

To machine a 45° cut, it is necessary to use the 45° support. Place the 45° support on the cutting table in the position required, fix the support to the carriage by locking the flywheel provided, then position the piece to be cut, after which it is possible to start the motor and commence cutting operations

15.3 CUTTING

For safe use of the machine when cutting, push the carriage forwards as the cut advances, placing your hands to the two sides of the carriage. Never push directly on the piece to be cut.

- Check that the blade is aligned with the cutting line.

- Place the workpiece on the worktable (ref. 8, fig. 1), resting firmly against the stop.

- Start the engine.

- Wait until the water reaches the blade.

- Begin cutting.

- Horizontal cutting movement is carried out by pulling the carriage towards the blade.

- As cutting thickness increases, the blade is subjected to greater stress. To avoid overloading the engine, the operator should continually check blade feed speed. The speed will also depend on the characteristics of the material being cut (hardness, toughness etc.).



15.3.1 CUTTING WITH CUTTING WHEEL LOWERED FROM ABOVE.

Adjust the vertical height by turning the crank (ref.11, fig.1), position the piece to be cut, start the panel saw and commence cutting operations by pressing the pedal (ref.16, fig.1) to lower the wheel from above.

15.3.2 BLADE CHANGE

To change the blade refer to section 14.

16. USING 22"IN. DIAMETER CUTTING WHEEL.

If an optional cutting wheel diameter 22" in. is used instead of the standard wheel diameter 20" in. , it is important that the stop bolt be calibrated to prevent interference between the wheel and the carriage when the head is in the lowest position.

- **Warning. The panel saw is fitted with a stop bolt to stop the cutting wheel in the lowest vertical position. This stop is calibrated for a 20" in. cutting wheel. If you are using a 22" in. cutting wheel, loosen the bolt (ref. 17, fig. 1), lower the wheel to the lowest position, by turning the crank, then check, with the motor turned off, that there is no interference between the cutting wheel and the piece holder carriage when the pedal is pressed. Adjust the bolt, bring it into contact with the stop and tighten the lock nut.**

- **Note that the blade must have an external diameter of 22" in., a central hole diameter of 1" in. and max. thickness of 1/8" in.**

17. MAINTENANCE

- **WARNING! Servicing must always be carried out by qualified technicians and only after the motor has been switched off.**

- **WARNING! Recommended product for cleaning mechanical parts: WD-40.**

- **Always keep the guards in proper working order and free from damage. Take particular care to ensure that the blade guards are kept efficient and clean, replacing them if they are damaged**

- **As there is the continuous risk of inadvertent damage to the electric cables, these must be checked regularly each time before the machine is used.**

Do not leave the machine outside: it must always be protected from the weather.

Below is a list of the cleaning operations that must be carried out at the end of every shift.

17.1 TANK CLEANING

Empty the tank by removing the drain plug. Remove cutting residue using a jet of water.

17.2 TANK REMOVAL (Ref.Fig.7).

Empty the drum opening the drum cap from right or left side.

17.3 WORK SURFACE CLEANING

Always keep work surfaces clean. Residual dirt can impair cutting precision.

17.4 GUIDE RAIL CLEANING

It is good practice to remove all traces of dirt from the guides.

17.5 CLEANING AND MAINTENANCE OF COOLING CIRCUIT

- If water does not reach the blade stop the machine immediately to avoid blade damage.

- After switching off the machine ensure that the water level is sufficient.
- Check that there is water in the pump by unscrewing the connector, and if necessary top up until water flows out (fig.10).

- **WARNING. Before starting the panel saw for the first time, or when starting it after long periods of inactivity, fill the pump with water as described above**

- At the end of every shift, unscrew the suction hose filter and clean it. Then, circulate some water through it placing inside a bucket of clean water.

17.6 CLEANING AND MAINTENANCE OF COOLING

CIRCUIT

- If water does not reach the blade stop the machine immediately to avoid blade damage.

- After switching off the machine ensure that the water level is sufficient.

- If necessary, after disconnecting the machine from the power supply check that the tap, hose and pump filter are not blocked

17.7 TENSIONING THE DRIVE BELT (fig. 8)

- Switch off the electric motor and remove the plug from the power supply.

- Unscrew the 4 screws that secure the movable belt guard (ref. 1).

- Loosen the 4 (ref. 2) screws that clamp the electric motor to the blade support.

- Tension the belt using the nut (ref. 4): apply a force of about F=14lb. to the centre of the free section of the belt, the arrow should be about F=1/4" in.(fig. 9).

- Tighten the screws on the electric motor, checking the alignment of the motor pulley and the blade pulley

- Refit the guard and lock it using the 4 screws.

- **To avoid shortening the life of the belt, the bearings and the blade shaft, do not overtension the belt. Finally, check the two pulleys are aligned**

17.8 DRIVE BELT REPLACEMENT

Repeat the operations described in section 17.6, replacing the belt before tensioning it.

17.9 REPAIRS

- **Do not start the saw during repair work.**

Only use genuine IMER spare parts and do not modify them.

- **If the guards are removed to carry out repairs, they must be refitted properly when the repair work is finished.**

18. TROUBLESHOOTING

- **WARNING! Before carrying out any maintenance operations, switch off the machine, and remove the plug from the power socket**



FAULT	CAUSE	REMEDY
Motor does not start when switch is turned	- Defective power cable - Plug not inserted in socket correctly - Power cable from plug to control panel detached - Loose wire inside motor circuit board - A wire has become disconnected inside the panel - Faulty main switch - The overload safety device has been activated.	- Check power cables - Ensure correct connection - Connect cable- re - Connect wire - Remake the connection - Replace switch - Wait for a few minutes and then try restarting the machine.
Horizontal carriage movement not smooth	- Guide rails dirty	- Clean the guide rails
Lack of cooling water supply to blade	Refer to section 17.5: "cleaning and maintenance of cooling circuit" (Chapter 17.5)	
Blade does not cut	- Blade is worn - Drive belt not tensioned	- Fit new blade - Tension the belt
Motor starts but blade does not rotate	Belt is broken	Replace drive belt

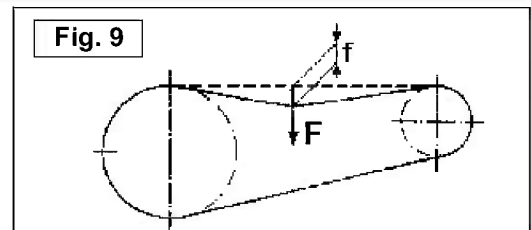
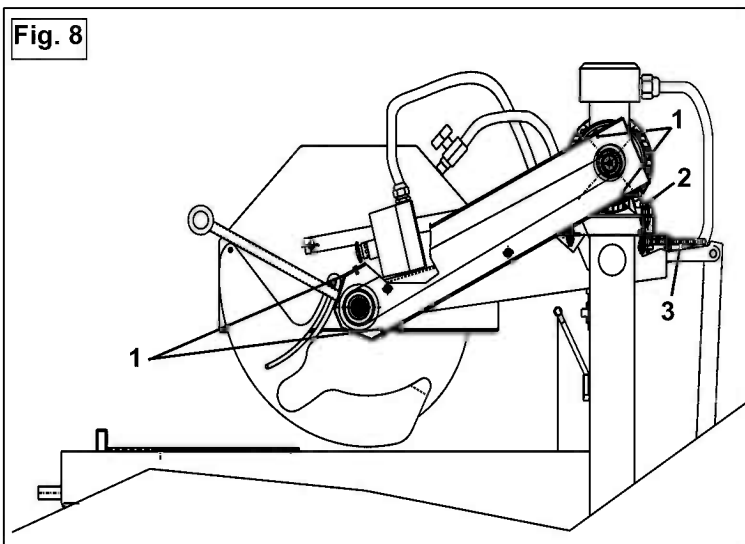
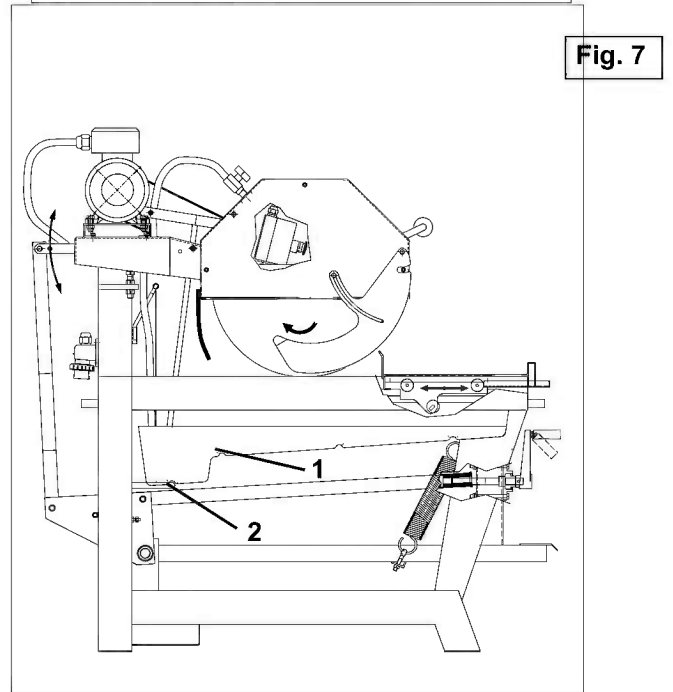
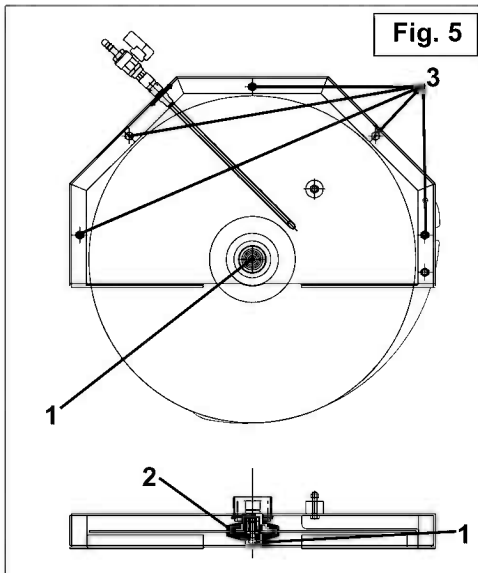
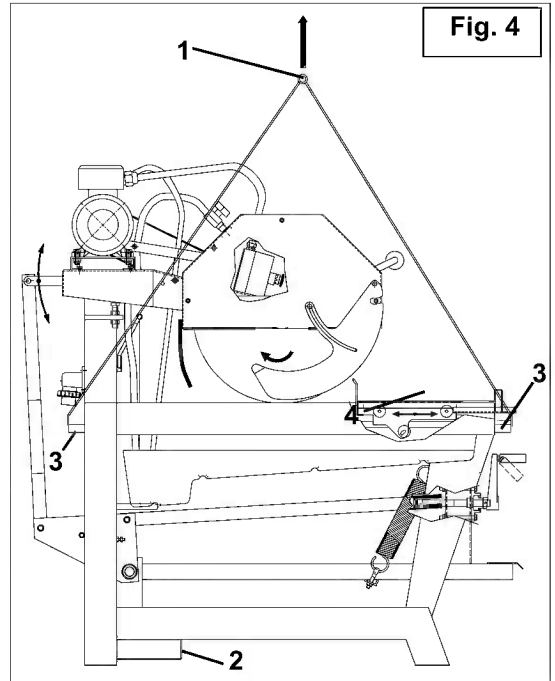
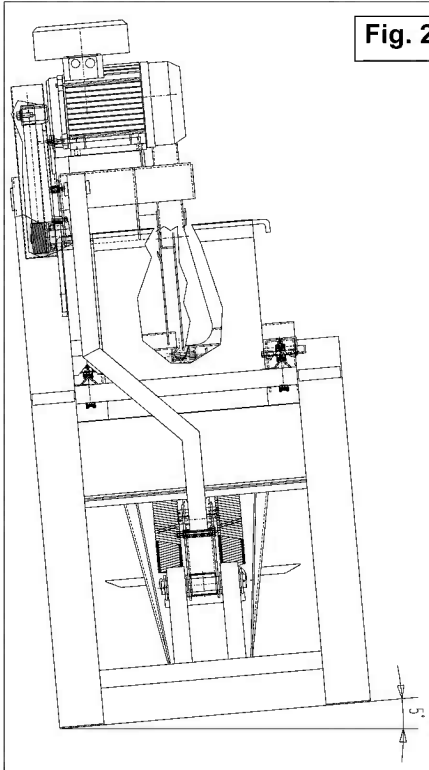



TAV.1

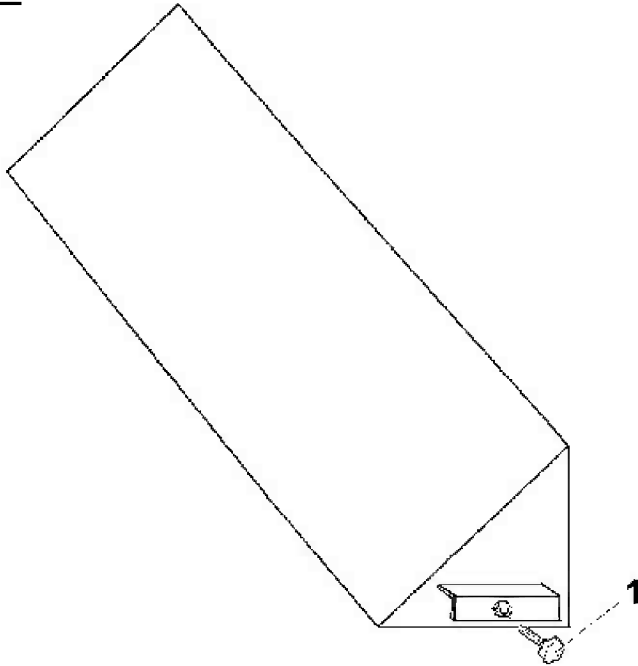

TAV.1 - 45° SUPPORT (cod.3210526)			
Rif.	Cod.	GB	Note
1	2284859	KNOB	

TAV.2

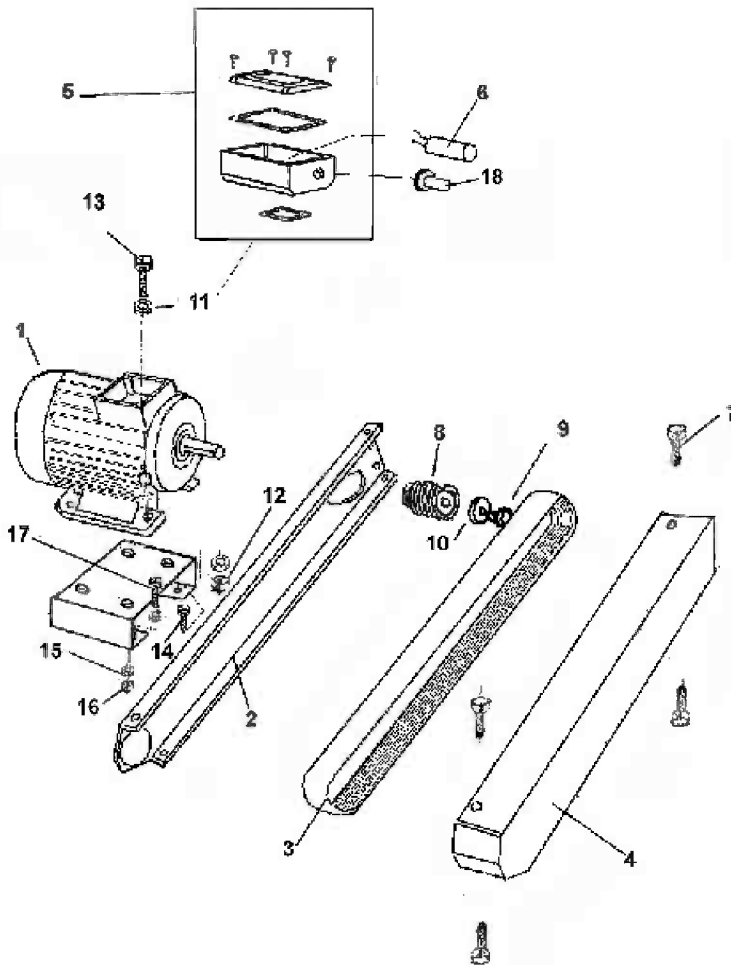

TAV.2 - ASSEMBLY OF MOTOR			
RIF.	COD.	GB	NOTE
1	3210714	MOTOR	230V/60HZ
2	3210539	BELTS EXTERNAL COVER	
3	3210570	BELT	560 J 12
4	3210740	BELTS INTERNAL COVER	
5	3210716	JUNCTION BOX	
6	3210721	CAPACITOR	μF 80 - 450V
7	3203921	BOLT	M 5X10 Z
8	3210573	PULLEY	
9	1222059	BOLT	M10X20
10	2224220	WASHER	10X40
11	2224380	STOP RING	12X25
12	2223700	SELF LOCKING NUT	M.12
13	2222181	BOLT	M 12X30
14	2222076	BOLT	M 8X25
15	2224140	WASHER	8X18
16	2223923	SELF LOCKING NUT	M.8
17	2222189	BOLT	M 8X45
18	3206170	POMP SWITCH	



TAV.3

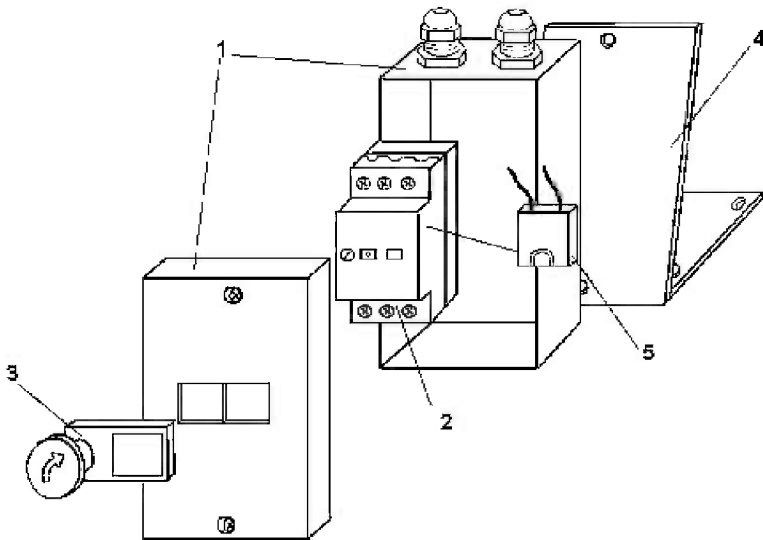

TAV.3 - ELECTRIC PANEL - code 3210713

RIF.	COD.		NOTE
1	3210462	JUNCTION BOX	
2	3207922	CONTACTOR	
3	3207928	PUSH	
4	3210356	ELECTRIC PANEL PLATE	
5	3207924	COIL	230v/60HZ

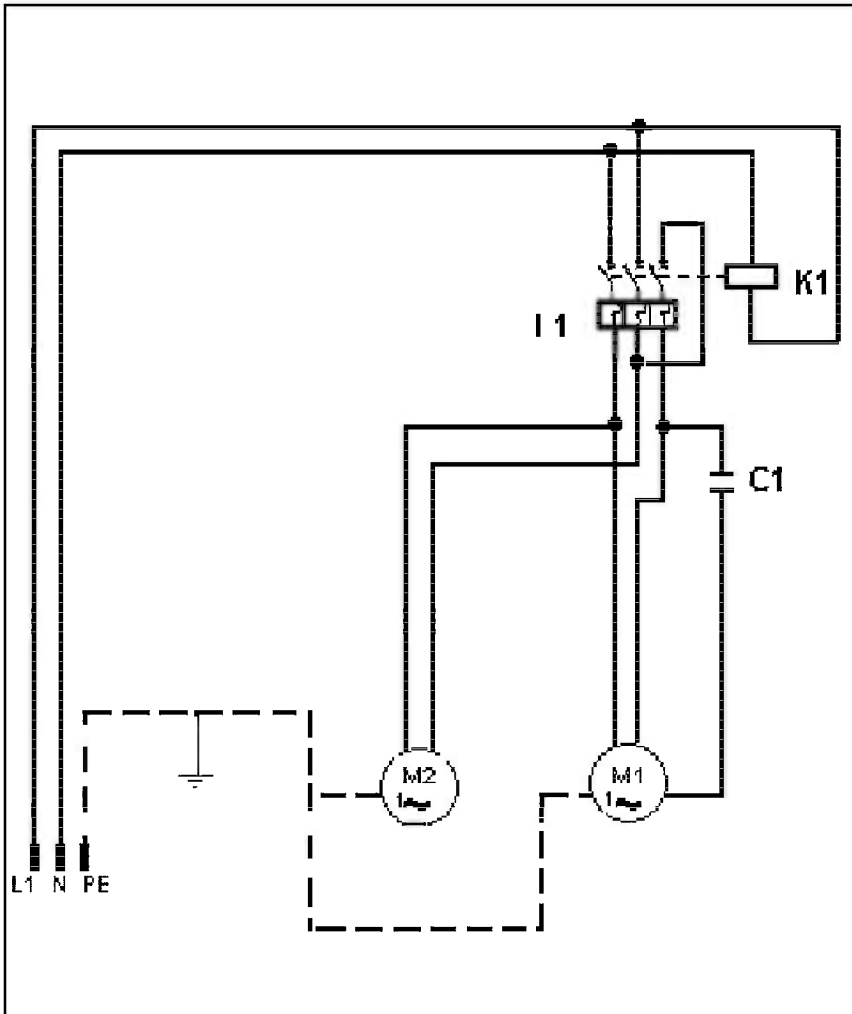

	GB	NOTE
L1	PHASE LINE CONDUCTOR	
N	NEUTRAL LINE CONDUCTOR	
PE	PROTECTION CONDUCTOR	
I1	THERMO-MAGNETIC CUTOUT SWITCH	
C1	MOTOR CAPACITOR	
K1	COIL	
M1	BLADE MOTOR	
M2	PUMP MOTOR	

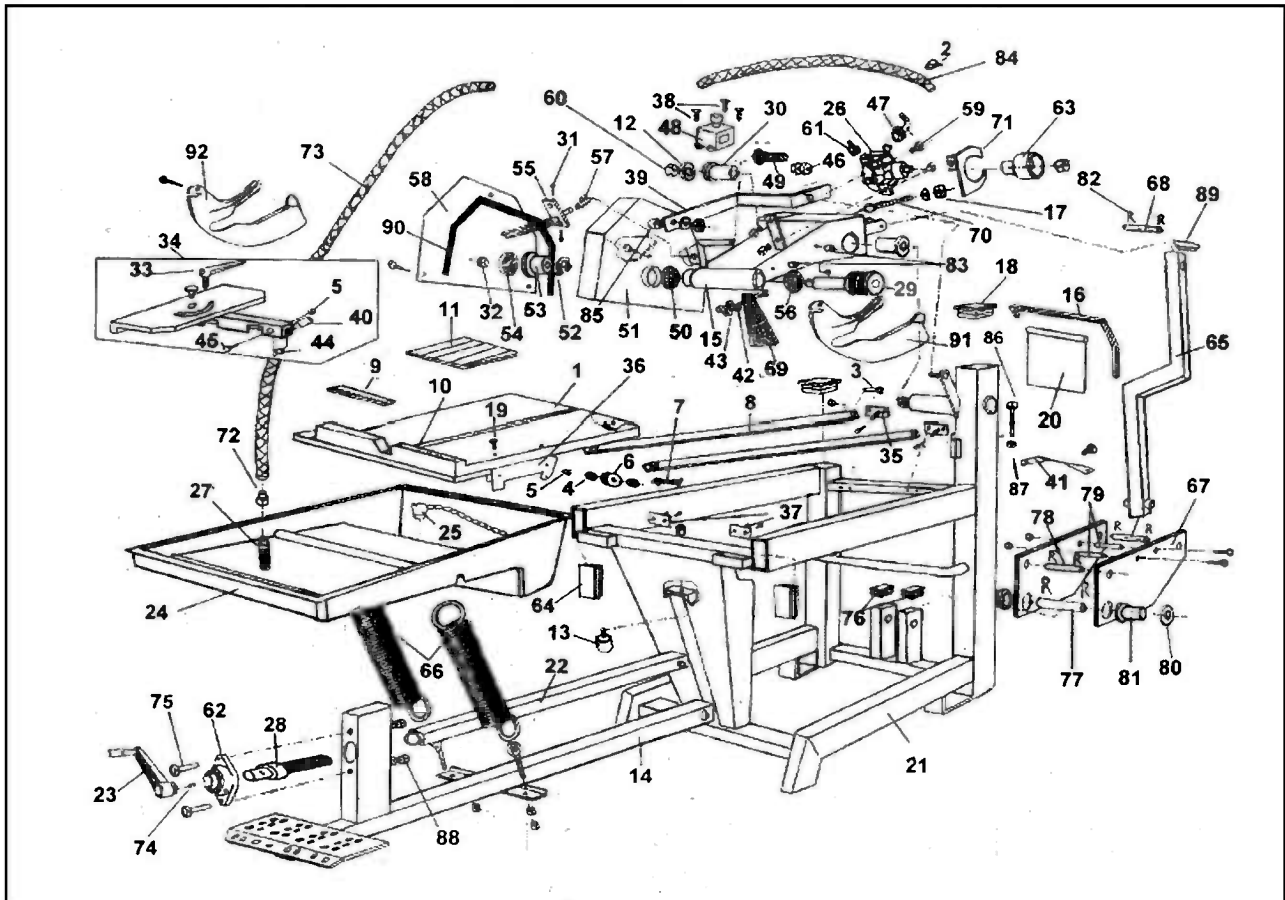

TAV.4 - MACHINE STRUCTURE			
RIF.	COD.	GB	NOTE
1	3208421	CARRIAGE	
2	3210577	SINGLE-PHASE COVER	
3	2222509	BOLT	5931 M 8X20
4	3204945	BEARING	608-2RS1
5	2223923	SELF LOCKING NUT	M.8
6	3207397	WHEEL	
7	2222090	BOLT	5737 M 8x75
8	3210311	GUIDE BAR	
9	3208442	LEFT FENCE ADHESIVE LABEL	
10	3208441	RIGHT FENCE ADHESIVE LABEL	
11	3205581	RUBBER COATING	
12	3210402	WASHER	
13	2265675	SHOCK ABSORBER	
14	3210342	PEDAL PIPE	
15	3210569	CUTTING HEAD GROUP	
16	3210407	SUPPORT	
17	2223920	SELF LOCKING NUT	M.10
18	3206965	PLUG	
19	2222587	SCREW	5933 M8X20
20	3210406	SPRAY GUARD	
21	3210249	FRAME	
22	3210270	ADJUSTING ROD PIPE.	
23	3210337	KNOB	
24	3210329	DRUM	
25	2235428	PLUG	
26	3210712	WATER PUMP	230V/60HZ
27	2227320	OIL SEAL RING	
28	3210313	SCREW	
29	3210571	SHAFT	
30	3213186	NYLON BUSHING	
31	2222002	SCREW	5739 M6x16
32	2222059	SCREW	5739 M8X25 Z SX.
33	3208414	LEVER	
34	3208422	GONIOMETER	
35	3207213	GUIDE BAR SUPPORT	
36	3208428	TROLLEY SLIDE	
37	3210236	GUIDE BAR SUPPORT SX	
38	2222580	SCREW	M4X20 Z
39	3210320	CUTTING WHEEL CASING ADJUSTMENT	
40	3209333	KNOB	M8
41	3208426	TROLLEY CLAMPING	
42	2224530	WASHER	
43	2223280	SCREW	
44	3209332	CAM	
45	2222018	SCREW	M4
46	2224140	WASHER	8x18 Z

TAV.4 - MACHINE STRUCTURE			
RIF.	COD.	GB	NOTE
46	2224140	WASHER	8x18 Z
47	3210356	ELECTRIC PANEL PLATE	
48	3210713	JUNCTION BOX	230V/60HZ
49	2288885	HANDGRIP	
50	3206513	BEARING	6205 2RS
51	3210301	DISC COVER	
52	3232759	OIL SEAL RING	35X52X7
53	3204777	INNER FLANGE	
54	3204776	OUTER FLANGE	
55	3210317	WATER HOSE	
56	3210629	BEARING	6006 2RS
57	2218075	VALVE	
58	3210322	BLADE COVER	
60	3210189	SELF LOCKING NUT	M.20
61	3210572	PULLEY	
62	2204655	SUPPORT	
64	3210346	PLUG	100x50x3
65	3210278	BLADE GUARD ROTATION ROD	
66	3210318	SPRING	DE 56.5
67	3210316	CALLIPER PLATE.	
68	3210325	CALLIPER PIN	
69	3210319	SPRAY GUARD	
70	3210353	TIE ROD SCREW	10X60
73	3210412	FILTER PIPE	
74	2228700	SNAP-PIN	
75	1222694	SCREW	M10 X110
76	3210345	PULLEY	80X40X3
77	3210323	FULCRUM PIN	
78	3210324	PEDAL PIN	
79	3210403	LOCKING PIPE	
80	1224323	WASHER	
81	2209400	NYLON BUSHING 30AP.	
82	2226700	SPLIT PIN	
83	3209329	SPACER BRACKET	
85	3210411	SPACER BRACKET	
86	2222130	BOLT	M16X50
87	2223806	NUT	D.16
88	2223650	NUT	D.10
89	2257705	PULLEY	
90	3210532	GASKET	
91	3210531	CUTTING WHEEL RH GUARD	
92	3210530	CUTTING WHEEL LH GUARD	

ONE YEAR WARRANTY

We warrant to the original purchaser that the IMER equipment described herein (the "equipment") shall be free from defects in material and workmanship under normal use and service for which it was intended for a period of one (1) year from the date of purchase by the original purchaser.

Our obligation under this warranty is expressly limited to replacing or repairing, free of charge, F.O.B. our designated service facility, such part or parts of the equipment as our inspection shall disclose to be defective. Parts such as engines, motors, pumps, valves, electric motors, etc. furnished by us but not manufactured by us will carry only the warranty of the manufacturer. Transportation charges or duties shall be borne by the purchaser. This shall be the limit of our liability with respect to the quality of the equipment.

This warranty shall not apply to any equipment, or parts thereof, which has been damaged by reason of accident, negligence, unreasonable use, faulty repairs, or which has not been maintained and operated in accordance with our printed instructions for our equipment. Further, this warranty is void if the equipment, or any of its components, is altered or modified in any way.

THIS WARRANTY IS EXPRESSLY IN LIEU OF ALL OTHER WARRANTIES, EXPRESSED OR IMPLIED, INCLUDING ANY IMPLIED WARRANTY OF MERCHANTABILITY OF FITNESS FOR A PARTICULAR PURPOSE.

We make no other warranty, representation or guarantee, nor is anyone authorized to make one on our behalf. We shall not be liable for any consequential damage of any kind, including loss or damage resulting, directly or indirectly, from the use or loss of use of the machine. Without limiting the generality of the foregoing, this exclusion from liability embraces the purchase's expenses for downtime, damages for which the purchaser may be liable to other persons, damages to property, and injury or death of any persons.

This warranty shall not be deemed to cover maintenance parts, including but not limited to blades, belts, hoses, hydraulic oil or filters, for which we shall have no responsibility or liability whatsoever.

IMER U.S.A., Inc.
207 Lawrence Avenue
South San Francisco, California 94080
(650) 872-2200